

SECTION **FAX**  
FRONT AXLE

A  
B  
C

FAX

CONTENTS

E

**2WD**

**SYMPTOM DIAGNOSIS** ..... 3

**NOISE, VIBRATION AND HARSHNESS (NVH) TROUBLESHOOTING** ..... 3  
NVH Troubleshooting Chart .....3

**PRECAUTION** ..... 4

**PRECAUTIONS** ..... 4  
Precaution for Supplemental Restraint System (SRS) "AIR BAG" and "SEAT BELT PRE-TENSIONER" .....4  
Precaution for Procedure without Cowl Top Cover....4

**PREPARATION** ..... 5

**PREPARATION** ..... 5  
Commercial Service Tool .....5

**PERIODIC MAINTENANCE** ..... 6

**FRONT WHEEL HUB AND KNUCKLE** ..... 6  
Inspection .....6

**REMOVAL AND INSTALLATION** ..... 7

**FRONT WHEEL HUB AND KNUCKLE** ..... 7  
Exploded View .....7  
Removal and Installation .....7  
Inspection .....8

**SERVICE DATA AND SPECIFICATIONS (SDS)** ..... 9

**SERVICE DATA AND SPECIFICATIONS (SDS)** ..... 9  
Wheel Bearing .....9

**AWD**

**SYMPTOM DIAGNOSIS** .....10

**NOISE, VIBRATION AND HARSHNESS (NVH) TROUBLESHOOTING** .....10  
NVH Troubleshooting Chart .....10

**PRECAUTION** .....11

**PRECAUTIONS** .....11  
Precaution for Supplemental Restraint System (SRS) "AIR BAG" and "SEAT BELT PRE-TENSIONER" .....11  
Precaution for Procedure without Cowl Top Cover...11  
Precautions for Drive Shaft .....11

**PREPARATION** .....13

**PREPARATION** .....13  
Special Service Tool .....13  
Commercial Service Tool .....14

**PERIODIC MAINTENANCE** .....15

**FRONT WHEEL HUB AND KNUCKLE** .....15  
Inspection .....15

**FRONT DRIVE SHAFT** .....16  
Inspection .....16

**REMOVAL AND INSTALLATION** .....17

**FRONT WHEEL HUB AND KNUCKLE** .....17  
Exploded View .....17  
Removal and Installation .....17  
Inspection .....18

**FRONT DRIVE SHAFT BOOT** .....19  
Exploded View .....19  
Replacement .....19

**FRONT DRIVE SHAFT** .....23  
Exploded View .....23  
Removal and Installation .....24  
Disassembly and Assembly .....24  
Inspection .....27

F

G

H

I

J

K

L

M

N

O

P

---

<b>SERVICE DATA AND SPECIFICATIONS</b>	
<b>(SDS)</b> .....	<b>29</b>

<b>SERVICE DATA AND SPECIFICATIONS</b>	
<b>(SDS)</b> .....	<b>29</b>
Wheel Bearing .....	29
Drive Shaft .....	29

# NOISE, VIBRATION AND HARSHNESS (NVH) TROUBLESHOOTING

< SYMPTOM DIAGNOSIS >

[2WD]

## SYMPTOM DIAGNOSIS

### NOISE, VIBRATION AND HARSHNESS (NVH) TROUBLESHOOTING

#### NVH Troubleshooting Chart

INFOID:000000007472535

Use chart below to find the cause of the symptom. If necessary, repair or replace these parts.

Reference		<a href="#">FAX-7</a>	—	<a href="#">FAX-6</a>	NVH in FAX and FSU sections	NVH in WT section	NVH in WT section	NVH in BR section	NVH in ST section
Possible cause and SUSPECTED PARTS		Improper installation, looseness	Parts interference	Wheel bearing damage	FRONT AXLE AND FRONT SUSPENSION	TIRE	ROAD WHEEL	BRAKE	STEERING
Symptom	FRONT AXLE	Noise	Shake	Vibration	Shimmy	Judder	Poor quality ride or handling		
		x	x	x	x	x	x	x	x
		x	x	x	x	x	x	x	x
		x	x	x	x	x	x	x	x
		x	x	x	x	x	x	x	x
		x	x	x	x	x	x	x	x
		x	x	x	x	x	x	x	x

x: Applicable

A  
B  
C  
E  
F  
G  
H  
I  
J  
K  
L  
M  
N  
O  
P

FAX

# PRECAUTION

## PRECAUTIONS

### Precaution for Supplemental Restraint System (SRS) "AIR BAG" and "SEAT BELT PRE-TENSIONER"

INFOID:000000007472536

The Supplemental Restraint System such as "AIR BAG" and "SEAT BELT PRE-TENSIONER", used along with a front seat belt, helps to reduce the risk or severity of injury to the driver and front passenger for certain types of collision. This system includes seat belt switch inputs and dual stage front air bag modules. The SRS system uses the seat belt switches to determine the front air bag deployment, and may only deploy one front air bag, depending on the severity of a collision and whether the front occupants are belted or unbelted. Information necessary to service the system safely is included in the "SRS AIR BAG" and "SEAT BELT" of this Service Manual.

**WARNING:**

Always observe the following items for preventing accidental activation.

- To avoid rendering the SRS inoperative, which could increase the risk of personal injury or death in the event of a collision that would result in air bag inflation, all maintenance must be performed by an authorized NISSAN/INFINITI dealer.
- Improper maintenance, including incorrect removal and installation of the SRS, can lead to personal injury caused by unintentional activation of the system. For removal of Spiral Cable and Air Bag Module, see "SRS AIR BAG".
- Never use electrical test equipment on any circuit related to the SRS unless instructed to in this Service Manual. SRS wiring harnesses can be identified by yellow and/or orange harnesses or harness connectors.

### PRECAUTIONS WHEN USING POWER TOOLS (AIR OR ELECTRIC) AND HAMMERS

**WARNING:**

Always observe the following items for preventing accidental activation.

- When working near the Air Bag Diagnosis Sensor Unit or other Air Bag System sensors with the ignition ON or engine running, never use air or electric power tools or strike near the sensor(s) with a hammer. Heavy vibration could activate the sensor(s) and deploy the air bag(s), possibly causing serious injury.
- When using air or electric power tools or hammers, always switch the ignition OFF, disconnect the battery, and wait at least 3 minutes before performing any service.

### Precaution for Procedure without Cowl Top Cover

INFOID:000000007472538

When performing the procedure after removing cowl top cover, cover the lower end of windshield with urethane, etc to prevent damage to windshield.

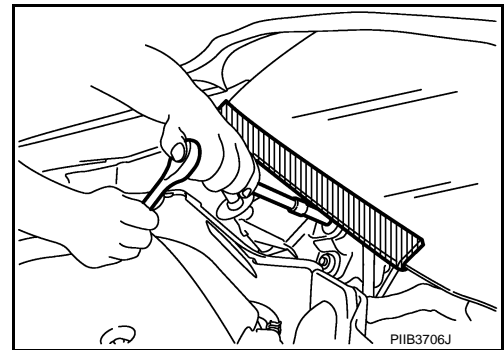

# PREPARATION

< PREPARATION >

[2WD]

## PREPARATION

### PREPARATION

#### Commercial Service Tool

INFOID:000000007472539

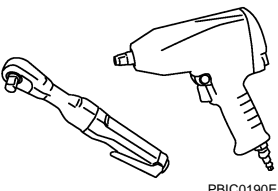
Tool name	Description
<p>Power tool</p>  <p>PBIC0190E</p>	<p>Loosening bolts and nuts</p>

A

B

C

FAX

E

F

G

H

I

J

K

L

M

N

O

P

## PERIODIC MAINTENANCE

### FRONT WHEEL HUB AND KNUCKLE

#### Inspection

INFOID:000000007472540

#### MOUNTING INSPECTION

Make sure that the mounting conditions (looseness, backlash) of each component and component conditions (wear, damage) are normal.

#### WHEEL BEARING INSPECTION

- Move wheel hub and bearing assembly in the axial direction by hand. Make sure there is no looseness of wheel bearing.

#### Standard

**Axial end play** : Refer to [FAX-9, "Wheel Bearing"](#).

- Rotate wheel hub and bearing assembly and make sure that is no unusual noise or other irregular conditions. If there is any of irregular conditions, replace wheel hub and bearing assembly.

# FRONT WHEEL HUB AND KNUCKLE

< REMOVAL AND INSTALLATION >

[2WD]

## REMOVAL AND INSTALLATION

### FRONT WHEEL HUB AND KNUCKLE

Exploded View

INFOID:000000007472541

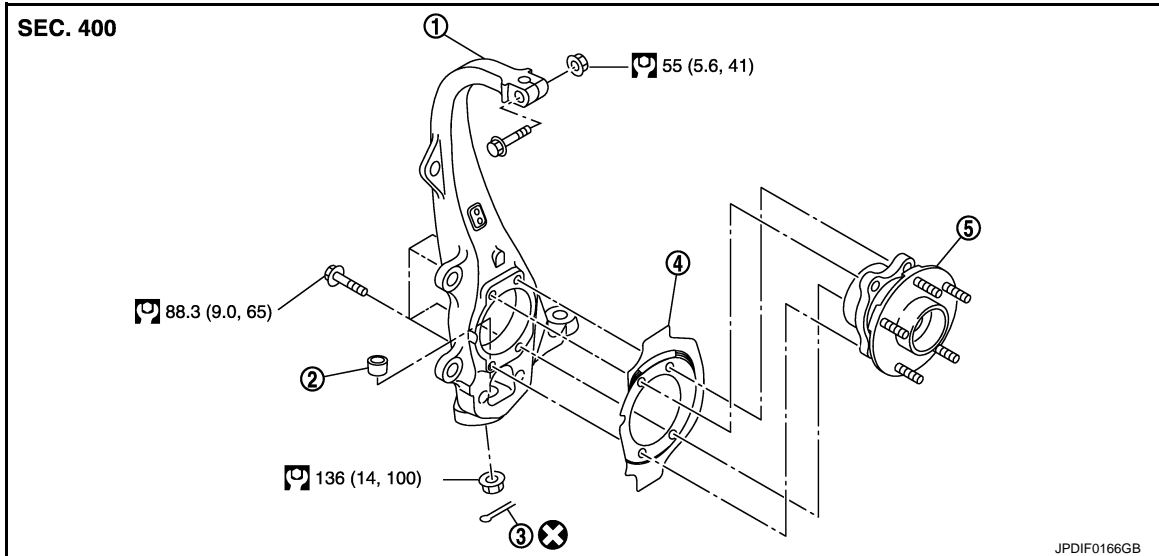

- |                     |                                   |               |
|---------------------|-----------------------------------|---------------|
| 1. Steering knuckle | 2. Ball seat                      | 3. Cotter pin |
| 4. Splash guard     | 5. Wheel hub and bearing assembly |               |

Refer to [GI-4, "Components"](#) for symbols in the figure.

### Removal and Installation

INFOID:000000007472542

#### REMOVAL

##### Wheel Hub and Bearing Assembly

1. Remove tires from vehicle with power tool.
2. Remove wheel sensor from steering knuckle. Refer to [BRC-115, "FRONT WHEEL SENSOR : Exploded View"](#).  
**CAUTION:**  
**Never pull on wheel sensor harness.**
3. Remove caliper assembly. Hang caliper assembly in a place where it will not interfere with work. Refer to [BR-44, "BRAKE CALIPER ASSEMBLY \(1 PISTON TYPE\) : Exploded View"](#) (1 piston type), [BR-48, "BRAKE CALIPER ASSEMBLY \(4 PISTON TYPE\) : Exploded View"](#) (4 piston type).  
**CAUTION:**  
**Never depress brake pedal while brake caliper is removed.**
4. Remove disc rotor. Refer to [BR-45, "BRAKE CALIPER ASSEMBLY \(1 PISTON TYPE\) : Removal and Installation"](#) (1 piston type), [BR-49, "BRAKE CALIPER ASSEMBLY \(4 PISTON TYPE\) : Removal and Installation"](#) (4 piston type).
5. Remove wheel hub and bearing assembly mounting bolts, and then remove splash guard and wheel hub and bearing assembly from steering knuckle.

##### Steering Knuckle

1. Remove wheel hub and bearing assembly, and then remove splash guard.
2. Remove brake hose bracket. Refer to [BR-20, "FRONT : Exploded View"](#).

# FRONT WHEEL HUB AND KNUCKLE

[2WD]

## < REMOVAL AND INSTALLATION >

3. Remove cotter pin (1) of steering outer socket, and then loosen the nut.
4. Remove steering outer socket (2) from steering knuckle (3) so as not to damage ball joint boot (4) using the ball joint remover.

**CAUTION:**

**Temporarily tighten the nut to prevent damage to threads and to prevent the ball joint remover from suddenly coming off.**

5. Remove cotter pin of transverse link and steering knuckle, and then loosen nut.
6. Separate upper link from steering knuckle.
7. Separate transverse link from steering knuckle so as not to damage ball joint boot using the ball joint remover.

**CAUTION:**

**Temporarily tighten the nut to prevent damage to threads and to prevent the ball joint remover from suddenly coming off.**

8. Remove steering knuckle from vehicle.

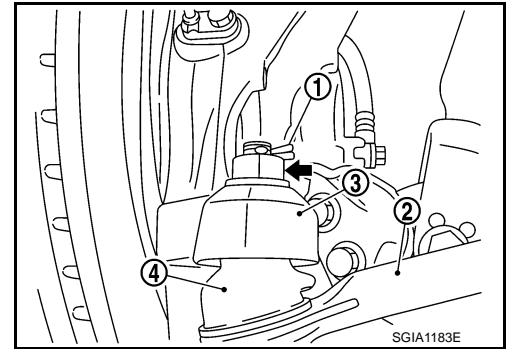

## INSTALLATION

Note the following, and install in the reverse order of the removal.

- Perform the final tightening of each of parts under conditions, which were removed when removing wheel hub and bearing assembly and steering knuckle.
- Never reuse cotter pin.

## Inspection

INFOID:000000007472543

### INSPECTION AFTER REMOVAL

Check components for deformation, cracks, and other damage. Replace if necessary.

#### Ball Joint Inspection

Check boots of transverse link and steering outer socket ball joint for breakage, axial play, and torque. Refer to [FSU-6, "Inspection"](#) and [ST-37, "2WD : Inspection"](#).

### INSPECTION AFTER INSTALLATION

- Check wheel sensor harness for proper connection. Refer to [BRC-115, "FRONT WHEEL SENSOR : Exploded View"](#).
- Check wheel alignment. Refer to [FSU-7, "Inspection"](#).
- Adjust neutral position of steering angle sensor. Refer to [BRC-9, "ADJUSTMENT OF STEERING ANGLE SENSOR NEUTRAL POSITION : Special Repair Requirement"](#).



# SERVICE DATA AND SPECIFICATIONS (SDS)

< SERVICE DATA AND SPECIFICATIONS (SDS)

[2WD]

## SERVICE DATA AND SPECIFICATIONS (SDS)

SERVICE DATA AND SPECIFICATIONS (SDS)

Wheel Bearing

INFOID:000000007472544

Item	Standard
Axial end play	0.05 mm (0.002 in) or less

A  
B  
C  
E  
F  
G  
H  
I  
J  
K  
L  
M  
N  
O  
P

FAX

# NOISE, VIBRATION AND HARSHNESS (NVH) TROUBLESHOOTING

< SYMPTOM DIAGNOSIS >

[AWD]

## SYMPTOM DIAGNOSIS

### NOISE, VIBRATION AND HARSHNESS (NVH) TROUBLESHOOTING

#### NVH Troubleshooting Chart

INFOID:000000007472545

Use chart below to find the cause of the symptom. If necessary, repair or replace these parts.

		Reference	—	<a href="#">FAX-2Z</a>	—	<a href="#">FAX-1Z</a>	—	<a href="#">FAX-15</a>	NVH in FAX and FSU sections	Refer to FRONT AXLE in this chart.	NVH in WT section	NVH in WT section	Refer to DRIVE SHAFT in this chart.	NVH in BR section	NVH in ST section	
		Possible cause and SUSPECTED PARTS	Excessive joint angle	Joint sliding resistance	Imbalance	Improper installation, looseness	Parts interference	Wheel bearing damage	FRONT AXLE AND FRONT SUSPENSION	FRONT AXLE	TIRE	ROAD WHEEL	DRIVE SHAFT	BRAKE	STEERING	
Symptom	DRIVE SHAFT	Noise	x	x				x	x	x	x	x		x	x	
		Shake	x		x			x	x	x	x	x		x	x	
	FRONT AXLE	Noise				x	x	x	x		x	x	x	x	x	x
		Shake				x	x	x	x		x	x	x	x	x	x
		Vibration				x	x	x	x		x		x			x
		Shimmy				x	x			x		x	x		x	x
		Judder				x				x		x	x		x	x
Poor quality ride or handling				x	x			x		x	x					

x: Applicable

# PRECAUTIONS

< PRECAUTION >

[AWD]

## PRECAUTION

### PRECAUTIONS

#### Precaution for Supplemental Restraint System (SRS) "AIR BAG" and "SEAT BELT PRE-TENSIONER"

INFOID:000000007472546

The Supplemental Restraint System such as "AIR BAG" and "SEAT BELT PRE-TENSIONER", used along with a front seat belt, helps to reduce the risk or severity of injury to the driver and front passenger for certain types of collision. This system includes seat belt switch inputs and dual stage front air bag modules. The SRS system uses the seat belt switches to determine the front air bag deployment, and may only deploy one front air bag, depending on the severity of a collision and whether the front occupants are belted or unbelted. Information necessary to service the system safely is included in the "SRS AIR BAG" and "SEAT BELT" of this Service Manual.

#### **WARNING:**

Always observe the following items for preventing accidental activation.

- To avoid rendering the SRS inoperative, which could increase the risk of personal injury or death in the event of a collision that would result in air bag inflation, all maintenance must be performed by an authorized NISSAN/INFINITI dealer.
- Improper maintenance, including incorrect removal and installation of the SRS, can lead to personal injury caused by unintentional activation of the system. For removal of Spiral Cable and Air Bag Module, see "SRS AIR BAG".
- Never use electrical test equipment on any circuit related to the SRS unless instructed to in this Service Manual. SRS wiring harnesses can be identified by yellow and/or orange harnesses or harness connectors.

#### PRECAUTIONS WHEN USING POWER TOOLS (AIR OR ELECTRIC) AND HAMMERS

#### **WARNING:**

Always observe the following items for preventing accidental activation.

- When working near the Air Bag Diagnosis Sensor Unit or other Air Bag System sensors with the ignition ON or engine running, never use air or electric power tools or strike near the sensor(s) with a hammer. Heavy vibration could activate the sensor(s) and deploy the air bag(s), possibly causing serious injury.
- When using air or electric power tools or hammers, always switch the ignition OFF, disconnect the battery, and wait at least 3 minutes before performing any service.

#### Precaution for Procedure without Cowl Top Cover

INFOID:000000007472548

When performing the procedure after removing cowl top cover, cover the lower end of windshield with urethane, etc to prevent damage to windshield.

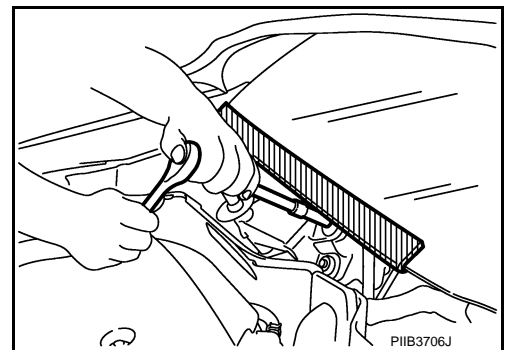

#### Precautions for Drive Shaft

INFOID:000000007472549

- Observe the following precautions when disassembling and assembling drive shaft.
- Never disassemble joint sub-assembly because it is non-overhaul parts.
- Perform work in a location which is as dust-free as possible.
- Clean the parts, before disassembling and assembling.
- Prevent the entry of foreign objects during disassembly of the service location.
- Reassemble disassembled parts carefully in the correct order. If work is interrupted, a clean cover must be placed over parts.
- Use paper waste. Fabric shop cloths must not be used because of the danger of lint adhering to parts.

## PRECAUTIONS

< PRECAUTION >

[AWD]

- 
- Clean disassembled parts (except for rubber parts) with kerosene which shall be removed by blowing with air or wiping with paper waste.

# PREPARATION

< PREPARATION >

[AWD]

## PREPARATION

### PREPARATION

#### Special Service Tool

INFOID:000000007472550

The actual shapes of Kent-Moore tools may differ from those of special service tools illustrated here.

Tool number (Kent-Moore No.) Tool name	Description
KV40107300 ( - ) Boot band crimping tool	Installing boot band
KV40107500 ( - ) Drive shaft attachment	Removing drive shaft
KV38107900 ( - ) Protector a: 32 mm (1.26 in) dia.	Installing drive shaft
KV38100500 ( - ) Drift a: 80 mm (3.15 in) dia. b: 60 mm (2.36 in) dia.	Installing drive shaft plug
KV38102200 ( - ) Drift a: 90 mm (3.54 in) dia. b: 31 mm (1.22 in) dia.	Installing drive shaft plug

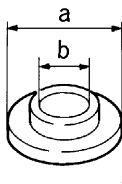
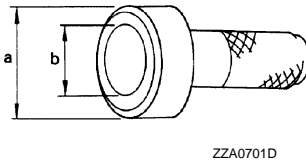
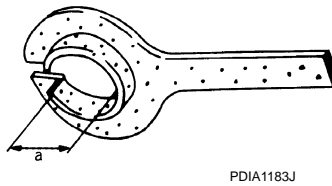
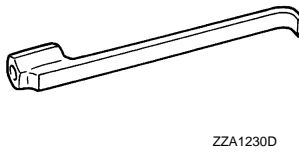
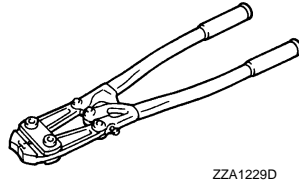

A  
B  
C  
FAX  
E  
F  
G  
H  
I  
J  
K  
L  
M  
N  
O  
P

# PREPARATION

< PREPARATION >

[AWD]

## Commercial Service Tool

INFOID:000000007472551

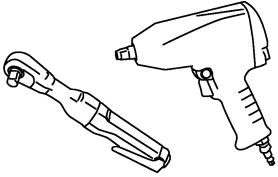
Tool name	Description
<p data-bbox="162 289 272 315">Power tool</p>  <p data-bbox="824 506 896 527">PBIC0190E</p>	<p data-bbox="1003 289 1260 315">Loosening bolts and nuts</p>

# FRONT WHEEL HUB AND KNUCKLE

< PERIODIC MAINTENANCE >

[AWD]

## PERIODIC MAINTENANCE

### FRONT WHEEL HUB AND KNUCKLE

#### Inspection

INFOID:000000007472552

#### MOUNTING INSPECTION

Make sure that the mounting conditions (looseness, backlash) of each component and component conditions (wear, damage) are normal.

#### WHEEL BEARING INSPECTION

- Move wheel hub and bearing assembly in the axial direction by hand. Make sure there is no looseness of wheel bearing.

#### Standard

**Axial end play** : Refer to [FAX-29, "Wheel Bearing"](#).

- Rotate wheel hub and bearing assembly and make sure that is no unusual noise or other irregular conditions. If there is any of irregular conditions, replace wheel hub and bearing assembly.

A  
B  
C  
FAX  
E  
F  
G  
H  
I  
J  
K  
L  
M  
N  
O  
P

## FRONT DRIVE SHAFT

< PERIODIC MAINTENANCE >

[AWD]

---

### FRONT DRIVE SHAFT

#### Inspection

INFOID:000000007472553

- Check drive shaft mounting point and joint for looseness and other damage.
- Check boot for cracks and other damage.

**CAUTION:**

**Replace entire drive shaft assembly when noise or vibration occurs from drive shaft.**



# FRONT WHEEL HUB AND KNUCKLE

< REMOVAL AND INSTALLATION >

[AWD]

## REMOVAL AND INSTALLATION

### FRONT WHEEL HUB AND KNUCKLE

Exploded View

INFOID:000000007472554

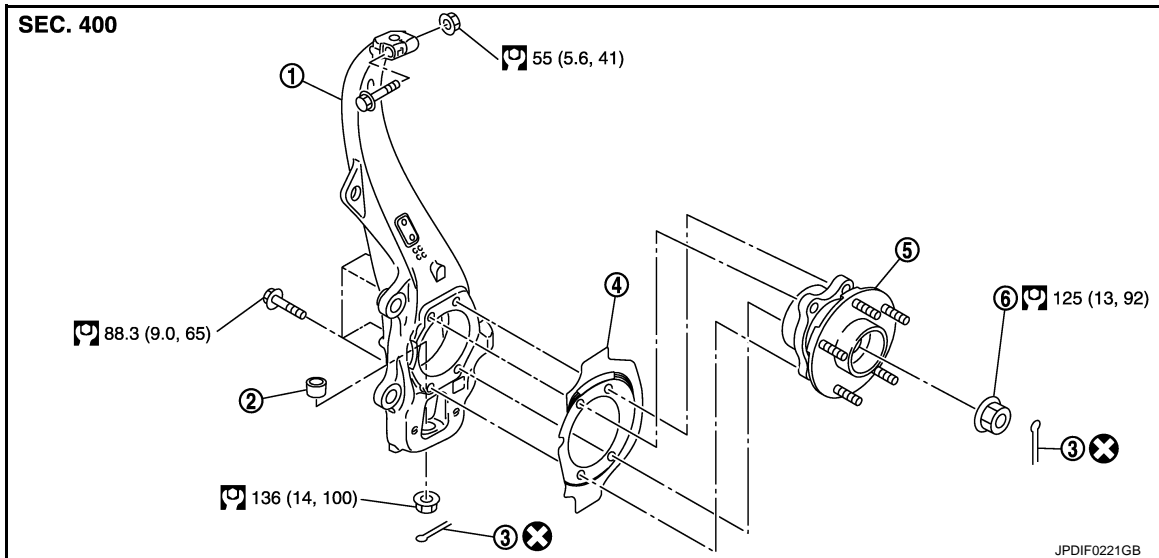

- |                     |                                   |                       |
|---------------------|-----------------------------------|-----------------------|
| 1. Steering knuckle | 2. Ball seat                      | 3. Cotter pin         |
| 4. Splash guard     | 5. Wheel hub and bearing assembly | 6. Wheel hub lock nut |

Refer to [GI-4, "Components"](#) for symbols in the figure.

## Removal and Installation

INFOID:000000007472555

### REMOVAL

#### Wheel Hub and Bearing Assembly

1. Remove tires with power tool.
2. Remove wheel sensor from steering knuckle. Refer to [BRC-115, "FRONT WHEEL SENSOR : Exploded View"](#).  
**CAUTION:**  
**Never pull on wheel sensor harness.**
3. Remove caliper assembly. Hang caliper assembly in a place where it will not interfere with work. Refer to [BR-44, "BRAKE CALIPER ASSEMBLY \(1 PISTON TYPE\) : Exploded View"](#) (1 piston type), [BR-42, "BRAKE PAD \(4 PISTON TYPE\) : Exploded View"](#) (4 piston type).  
**CAUTION:**  
**Never depress brake pedal while brake caliper is removed.**
4. Remove disc rotor. Refer to [BR-45, "BRAKE CALIPER ASSEMBLY \(1 PISTON TYPE\) : Removal and Installation"](#) (1 piston type), [BR-42, "BRAKE PAD \(4 PISTON TYPE\) : Exploded View"](#) (4 piston type).
5. Remove cotter pin, then loosen wheel hub lock nut with power tool.
6. Patch wheel hub lock nut with a piece of wood. Hammer the wood to disengage wheel hub and bearing assembly from drive shaft. Take out the wheel hub lock nut.  
**CAUTION:**
  - **Never place drive shaft joint at an extreme angle. Also be careful not to overextend slide joint.**
  - **Never allow drive shaft to hang down without support for housing (or joint sub-assembly), shaft and the other parts.****NOTE:**  
Use a suitable puller, if wheel hub and bearing assembly and drive shaft cannot be separated even after performing the above procedure.
7. Remove wheel hub and bearing assembly mounting bolts, and then remove splash guard and wheel hub and bearing assembly from steering knuckle.

# FRONT WHEEL HUB AND KNUCKLE

< REMOVAL AND INSTALLATION >

[AWD]

## Steering Knuckle

1. Remove wheel hub and bearing assembly, and then remove splash guard.
2. Remove brake hose bracket. Refer to [BR-20, "FRONT : Exploded View"](#).
3. Remove cotter pin (1) of steering outer socket, and then loosen the nut.
4. Remove steering outer socket (2) from steering knuckle (3) so as not to damage ball joint boot (4) using the ball joint remover.

### CAUTION:

**Temporarily tighten the nut to prevent damage to threads and to prevent the ball joint remover from suddenly coming off.**

5. Remove cotter pin of transverse link and steering knuckle, and then loosen nut.
6. Separate upper link from steering knuckle.
7. Separate transverse link from steering knuckle so as not to damage ball joint boot using the ball joint remover.

### CAUTION:

**Temporarily tighten the nut to prevent damage to threads and to prevent the ball joint remover from suddenly coming off.**

8. Remove steering knuckle from vehicle.

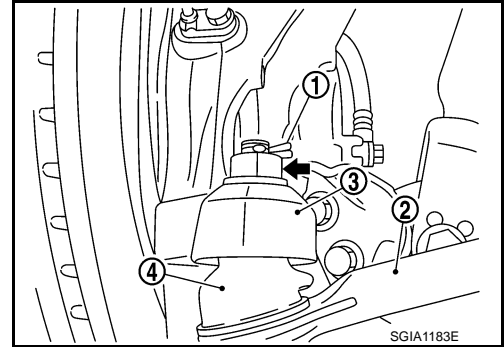

## INSTALLATION

Note the following, and install in the reverse order of the removal.

- Perform the final tightening of each of parts under unladen conditions, which were removed when removing wheel hub and bearing assembly and steering knuckle.
- Never reuse cotter pin.

## Inspection

INFOID:000000007472556

### INSPECTION AFTER REMOVAL

Check components for deformation, cracks, and other damage. Replace if necessary.

#### Ball Joint Inspection

Check boots of transverse link and steering outer socket ball joint for breakage, axial play, and torque. Refer to [FSU-37, "Inspection"](#) and [ST-47, "AWD : Inspection"](#).

### INSPECTION AFTER INSTALLATION

1. Check the wheel sensor harness for proper connection. Refer to [BRC-115, "FRONT WHEEL SENSOR : Exploded View"](#).
2. Check the wheel alignment. Refer to [FSU-29, "Inspection"](#).
3. Adjust neutral position of steering angle sensor. Refer to [BRC-9, "ADJUSTMENT OF STEERING ANGLE SENSOR NEUTRAL POSITION : Special Repair Requirement"](#).

# FRONT DRIVE SHAFT BOOT

< REMOVAL AND INSTALLATION >

[AWD]

## FRONT DRIVE SHAFT BOOT

### Exploded View

INFOID:000000007472557

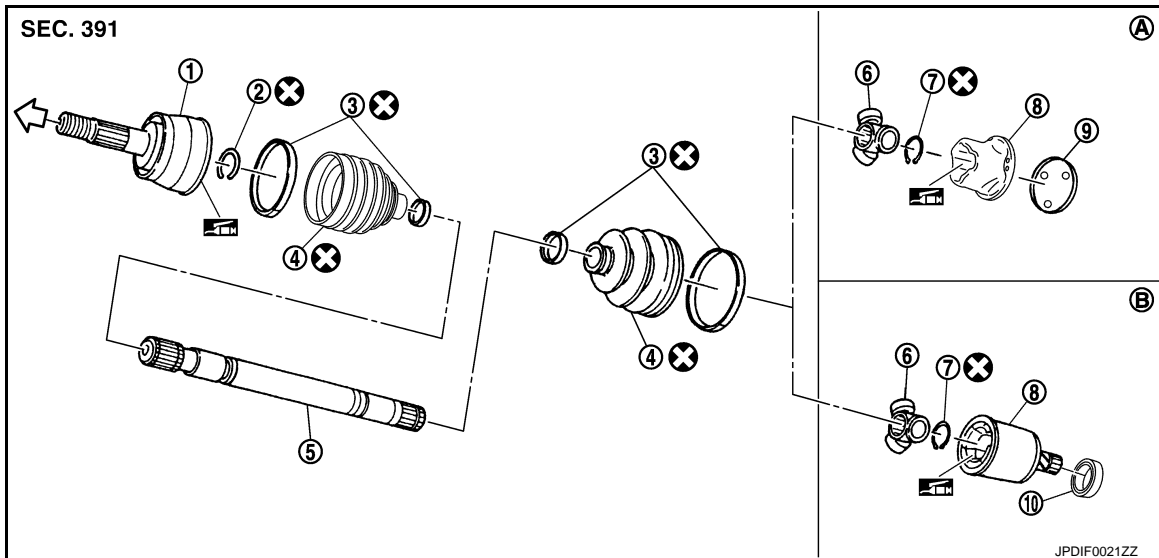

- |                       |                  |                    |
|-----------------------|------------------|--------------------|
| 1. Joint sub-assembly | 2. Circular clip | 3. Boot band       |
| 4. Boot               | 5. Shaft         | 6. Spider assembly |
| 7. Snap ring          | 8. Housing       | 9. Plug            |
| 10. Dust shield       |                  |                    |
| A. Left side          | B. Right side    |                    |

← Wheel side

 NISSAN genuine grease or an equivalent.

Refer to [GI-4, "Components"](#) for symbols not described on the above.

## Replacement

INFOID:000000007472558

### WHEEL SIDE

1. Remove tires with power tool.
2. Remove wheel sensor from steering knuckle. Refer to [BRC-115, "FRONT WHEEL SENSOR : Exploded View"](#).  
**CAUTION:**  
**Never pull on wheel sensor harness.**
3. Remove brake hose bracket. Refer to [BR-20, "FRONT : Exploded View"](#).
4. Remove caliper assembly. Hang caliper assembly a place where it will not interfere with work. Refer to [BR-44, "BRAKE CALIPER ASSEMBLY \(1 PISTON TYPE\) : Exploded View"](#) (1 piston type), [BR-42, "BRAKE PAD \(4 PISTON TYPE\) : Exploded View"](#) (4 piston type).  
**CAUTION:**  
**Never depress brake pedal while brake caliper is removed.**
5. Remove disc rotor. Refer to [BR-45, "BRAKE CALIPER ASSEMBLY \(1 PISTON TYPE\) : Removal and Installation"](#) (1 piston type), [BR-42, "BRAKE PAD \(4 PISTON TYPE\) : Exploded View"](#) (4 piston type).
6. Remove cotter pin, then loosen wheel hub lock nut with a power tool.
7. Patch wheel hub lock nut with a piece of wood. Hammer the wood to disengage wheel hub and bearing assembly from drive shaft. Take out the wheel hub lock nut.  
**CAUTION:**
  - Never place drive shaft joint at an extreme angle. Also be careful not to overextend slide joint.
  - Never allow drive shaft to hang down without support for housing (or joint sub-assembly), shaft and the other parts.

**NOTE:**

## FRONT DRIVE SHAFT BOOT

[AWD]

### < REMOVAL AND INSTALLATION >

Use a suitable puller if wheel hub and bearing assembly and drive shaft cannot be separated even after performing the above procedure.

8. Remove cotter pin (1) of steering outer socket, and then loosen the nut.

9. Remove steering outer socket (2) from steering knuckle (3) so as not to damage ball joint boot (4) using the ball joint remover.

**CAUTION:**

**Temporarily tighten the nut to prevent damage to threads and to prevent the ball joint remover from suddenly coming off.**

10. Remove cotter pin of transverse link and steering knuckle, and then loosen nut.

11. Separate transverse link from steering knuckle so as not to damage ball joint boot using the ball joint remover.

**CAUTION:**

**Temporarily tighten the nut to prevent damage to threads and to prevent the ball joint remover from suddenly coming off.**

12. Remove drive shaft from wheel hub and bearing assembly.

13. Remove boot bands, and then remove boot from joint sub-assembly.

14. Screw a drive shaft puller (A) into joint sub-assembly screw part to a length of 30 mm (1.18 in) or more. Support drive shaft with one hand and pull out joint sub-assembly with a sliding hammer (B) from shaft.

**CAUTION:**

- Align a sliding hammer and drive shaft and remove them by pulling firmly and uniformly.
- If joint sub-assembly cannot be pulled out, try after removing drive shaft from vehicle.

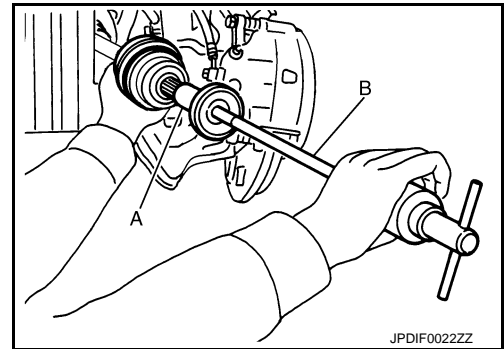
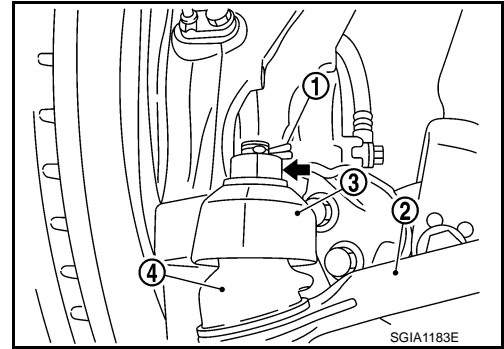

15. Remove the circular clip (1) from shaft.

16. Remove boot from shaft.

17. Clean the old grease on joint sub-assembly with paper waste.

18. Fill serration slot joint sub-assembly with NISSAN genuine grease or equivalent until the serration slot and ball groove become full to the brim.

**CAUTION:**

**After applying grease, use a paper waste to wipe off old grease that has oozed out.**

19. Install boot and boot bands to shaft.

**CAUTION:**

- Wrap serration on shaft with tape to protect the boot from damage.
- Never reuse boot and boot band.

20. Remove the tape wrapped around the serration on shaft.

21. Position circular clip on groove at the shaft edge.

**CAUTION:**

**Never reuse circular clip.**

**NOTE:**

Drive joint inserter is recommended when installing circular clip.

22. Align both center axes of the shaft edge and joint sub-assembly. Then assemble shaft with circular clip joint sub-assembly.

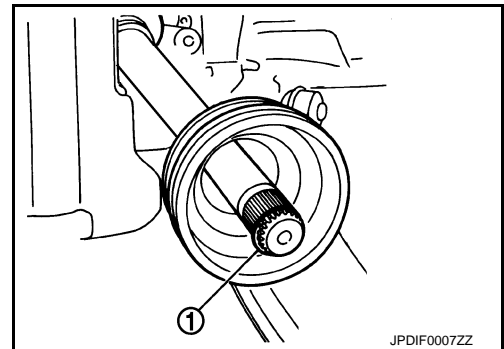

# FRONT DRIVE SHAFT BOOT

[AWD]

## < REMOVAL AND INSTALLATION >

23. Install joint sub-assembly (1) to shaft using plastic hammer.

**CAUTION:**

**Confirm that joint sub-assembly is correctly engaged while rotating drive shaft.**

24. Apply the balance of the specified amount of grease into the boot inside from large diameter side of boot.

**Standard**

**Grease amount** : Refer to [FAX-29, "Drive Shaft"](#).

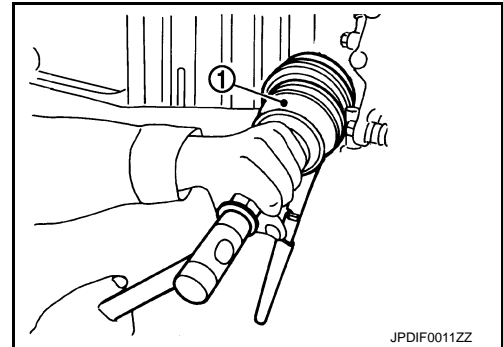

25. Install the boot securely into grooves (indicated by "\*" marks) shown in the figure.

**CAUTION:**

**If grease adheres to the boot mounting surface (with "\*" mark) on the shaft or joint sub-assembly, boot may come off. Remove all grease from the surface.**

26. To prevent the deformation of the boot, adjust the boot installation length (L) to the specified value shown below by inserting the suitable tool into inside of the boot from the large diameter side of the boot and discharging the inside air.

**Standard**

**Boots installed length (L)** : Refer to [FAX-29, "Drive Shaft"](#).

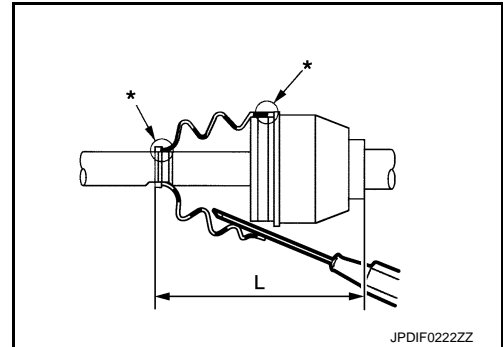

**CAUTION:**

- If the boot installation length is outside the standard, it may cause breakage of boot.
- Be careful not to touch the inside of the boot with a tip of tool.

27. Secure the large and small ends of the boot with boot bands using the boot band crimping tool (A) [SST: KV40107300 ( - )].

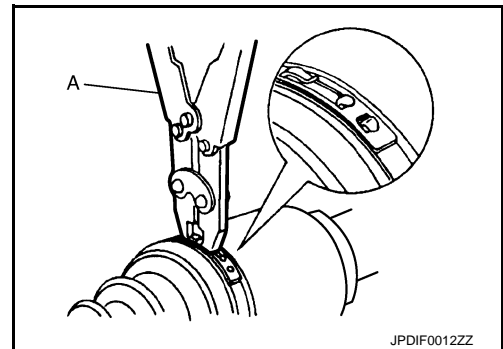

**NOTE:**

Secure boot band so that dimension (M) meets the specification as shown in the figure.

**Dimension (M)** : 2.0 – 3.0 mm (0.079 – 0.118 in)

28. Secure joint sub-assembly and shaft, and then make sure that they are in the correct position when rotating boot. Install them with boot band when boot installation positions become incorrect.

29. Insert drive shaft to wheel hub and bearing assembly, and then temporarily tighten wheel hub lock nut.

**CAUTION:**

- The drive shaft is press-fit. When assembling the shaft, never press it, but pull it until fully seated by tightening the wheel hub lock nut.
- Check that anticorrosive oil is applied to the thread of the drive shaft. If not, apply appropriate oil such as engine oil.

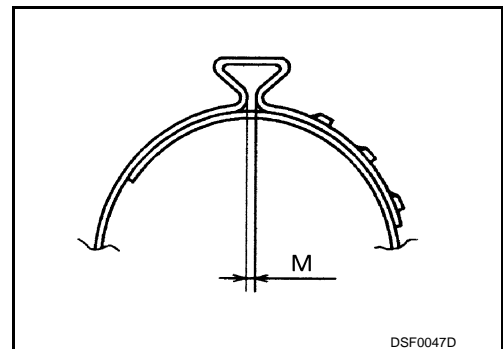

## FRONT DRIVE SHAFT BOOT

< REMOVAL AND INSTALLATION >

[AWD]

- If sufficient oil is not applied to the thread of the drive shaft, the wheel hub lock nut may be seized and the tightening torque reaches the specified limit prematurely. It may cause looseness or abnormal noises.
30. Install transverse link to steering knuckle. Refer to [FAX-17, "Exploded View"](#).
  31. Install steering outer socket to steering knuckle. Refer to [ST-38, "AWD : Exploded View"](#).
  32. Install disc rotor. Refer to [BR-45, "BRAKE CALIPER ASSEMBLY \(1 PISTON TYPE\) : Removal and Installation"](#) (1 piston type), [BR-42, "BRAKE PAD \(4 PISTON TYPE\) : Exploded View"](#) (4 piston type).
  33. Install caliper assembly to steering knuckle. Refer to [BR-44, "BRAKE CALIPER ASSEMBLY \(1 PISTON TYPE\) : Exploded View"](#) (1 piston type), [BR-42, "BRAKE PAD \(4 PISTON TYPE\) : Exploded View"](#) (4 piston type).
  34. Install brake hose bracket to steering knuckle. Refer to [BR-20, "FRONT : Exploded View"](#).
  35. Install wheel sensor to steering knuckle. Refer to [BRC-115, "FRONT WHEEL SENSOR : Exploded View"](#).
  36. Tighten the wheel hub lock nut to the specified torque. Refer to [FAX-17, "Exploded View"](#).
  37. Install cotter pin.

**CAUTION:**

- Never reuse cotter pin.
- Bend it at the root sufficiently to prevent any looseness.

# FRONT DRIVE SHAFT

< REMOVAL AND INSTALLATION >

[AWD]

## FRONT DRIVE SHAFT

Exploded View

INFOID:000000007472559

### REMOVAL

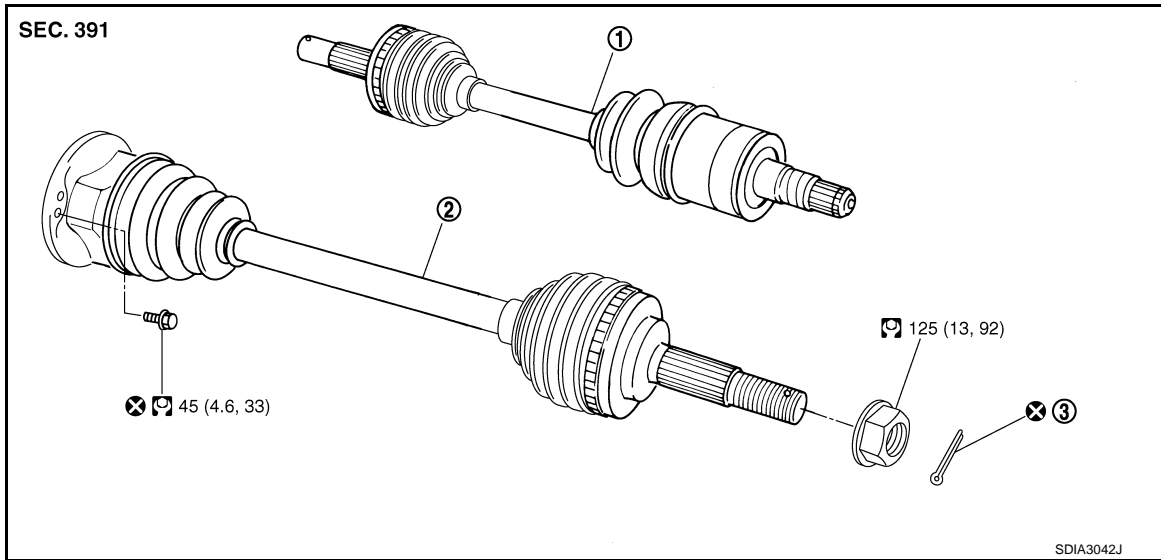

1. Drive shaft (right side)
2. Drive shaft (left side)
3. Cotter pin

Refer to GI section for symbols in the figure.

### DISASSEMBLY

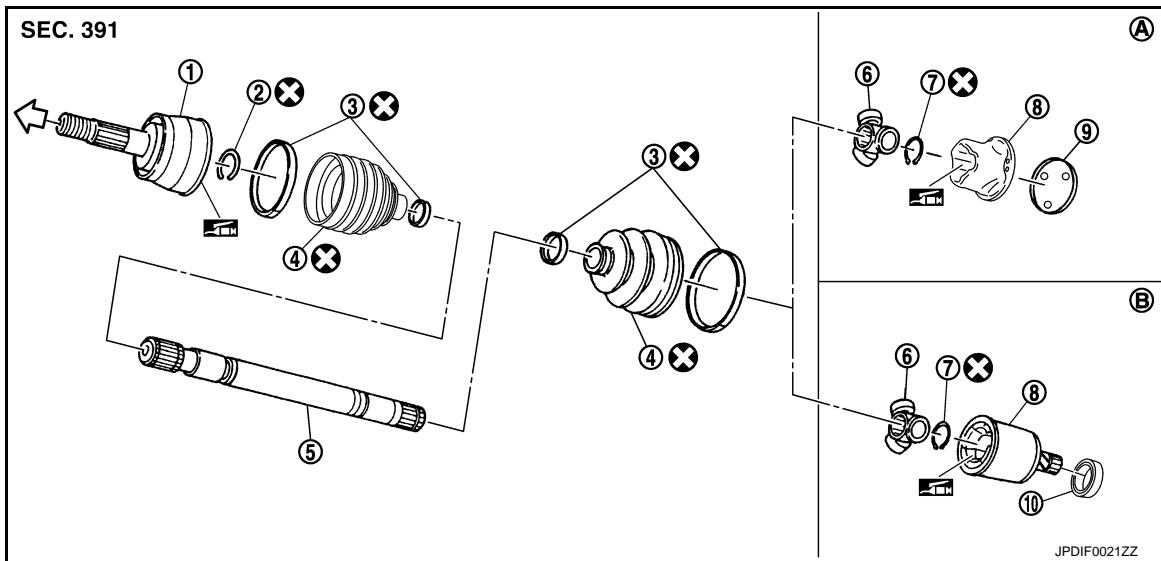

1. Joint sub-assembly
  2. Circular clip
  3. Boot band
  4. Boot
  5. Shaft
  6. Spider assembly
  7. Snap ring
  8. Housing
  9. Plug
  10. Dust shield
- A. Left side  
B. Right side

⇐: Wheel side

: NISSAN genuine grease or an equivalent.

Refer to [GI-4, "Components"](#) for symbols not described on the above.



# FRONT DRIVE SHAFT

[AWD]

< REMOVAL AND INSTALLATION >

## Removal and Installation

INFOID:000000007472560

### REMOVAL

#### Left Side

1. Refer to the procedure from 1 to 12 in [FAX-19, "Replacement"](#).
2. Remove shock absorber from transverse link with power tool. Refer to [FSU-31, "Exploded View"](#).
3. Remove fixing bolts and nuts, and then remove drive shaft from vehicle.

#### Right Side

1. Refer to the procedure from 1 to 12 in [FAX-19, "Replacement"](#).
2. Remove shock absorber from transverse link with power tool. Refer to [FSU-31, "Exploded View"](#).
3. Remove drive shaft from front final drive.
  - Remove drive shaft from front final drive using the drive shaft attachment (A) [SST:KV40107500 ( - )] and a sliding hammer (B) while inserting tip of the drive shaft attachment between housing and front final drive.

#### CAUTION:

**Never place drive shaft joint at an extreme angle when removing drive shaft. Also be careful not to overextend slide joint.**

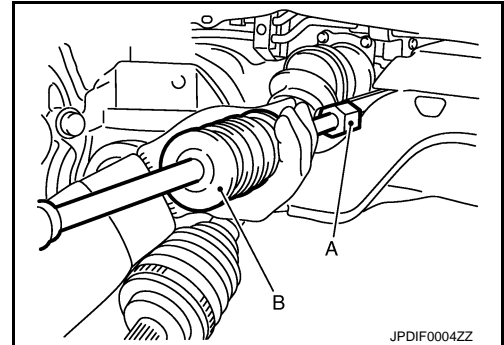

### INSTALLATION

#### Left Side

Install in the reverse order of removal.

#### Right Side

Note the following, and install in the reverse order of removal.

#### CAUTION:

**Always replace front final drive oil seal with new one when installing drive shaft. Refer to [DLN-119, "RIGHT SIDE : Exploded View"](#) (Right side), [DLN-120, "LEFT SIDE : Exploded View"](#) (Left side).**

- Place the protector (A) [SST:KV38107900 ( - )] onto front final drive to prevent damage to the oil seal while inserting drive shaft. Slide drive shaft sliding joint and tap with a hammer to install securely.

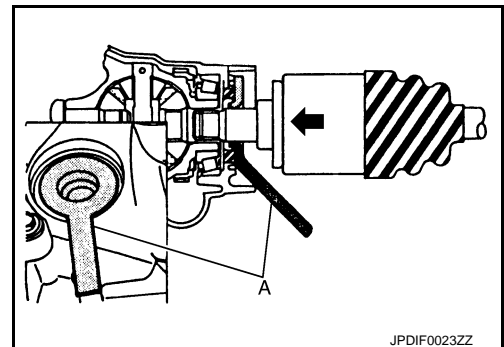

### Disassembly and Assembly

INFOID:000000007472561

### DISASSEMBLY

#### Front Final Drive Side

1. Fix shaft with a vise.
  - CAUTION:**  
**Protect shaft when fixing with a vise using aluminum or copper plates.**
2. Remove boot bands, and then remove boot from housing.
3. Put matching marks on housing and shaft, and then pull out housing from shaft.
  - CAUTION:**  
**Use paint or similar substance for matching marks. Never scratch the surfaces.**



# FRONT DRIVE SHAFT

[AWD]

## < REMOVAL AND INSTALLATION >

- Put matching marks (A) on the spider assembly and shaft.

**CAUTION:**

**Use paint or similar substance for matching marks. Never scratch the surfaces.**

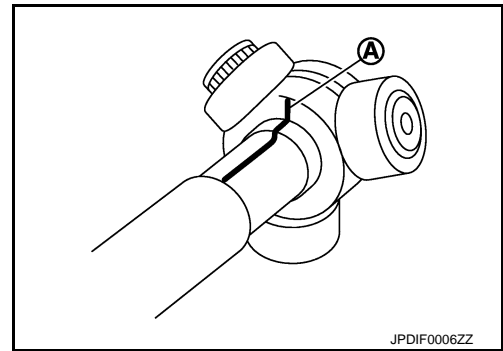

- Remove snap ring (1), and then remove spider assembly from the shaft.
- Remove boot from the shaft.
- Remove dust shield from housing. (right side)
- If plug needs to be removed, move boot to wheel side, and take it out with a plastic hammer. (left side)

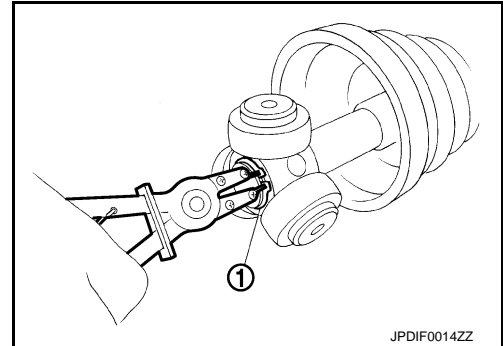

### Wheel Side

- Fix shaft with a vise.

**CAUTION:**

**Protect shaft when fixing with a vise using aluminum or copper plates.**

- Remove boot bands, and then remove boot from joint sub-assembly.
- Screw the drive shaft puller (A) 30 mm (1.18 in) or more into the thread of joint sub-assembly, and pull joint sub-assembly with a sliding hammer (B) from shaft.

**CAUTION:**

- If joint sub-assembly cannot be removed after five or more unsuccessful attempts, replace shaft and joint sub assembly as a set.
- Align sliding hammer and drive shaft and remove them by pulling directory.

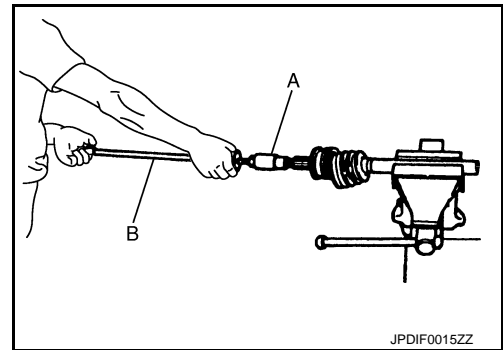

- Remove circular clip from shaft.
- Remove boot from shaft.
- Clean old grease on joint sub-assembly with paper waste while rotating ball cage.

## ASSEMBLY

### Front Final Drive Side

- Clean old grease on housing with paper waste.
- If plug (1) has been removed, use a drift to press in a new one. (left side)

←: Press

A: Drift [SST: KV38100500 ( - )]

B: Drift [SST: KV38102200 ( - )]

- Install new boot and boot bands to shaft.

**CAUTION:**

- Wrap serration on shaft with tape to protect boot from damage.

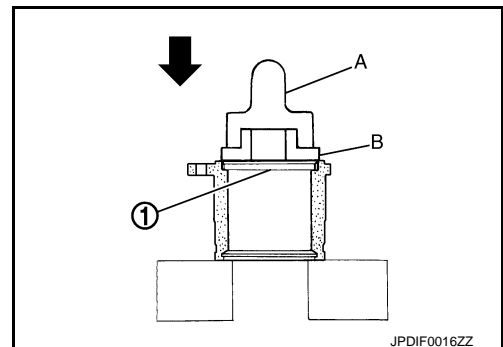

# FRONT DRIVE SHAFT

[AWD]

## < REMOVAL AND INSTALLATION >

• **Never reuse boot and boot band.**

4. Remove the tape wrapped around the serration on shaft.
5. To install the spider assembly (1), align it with the matching marks (A) on the shaft (2) during the removal, and direct the serration mounting surface (B) to the shaft.

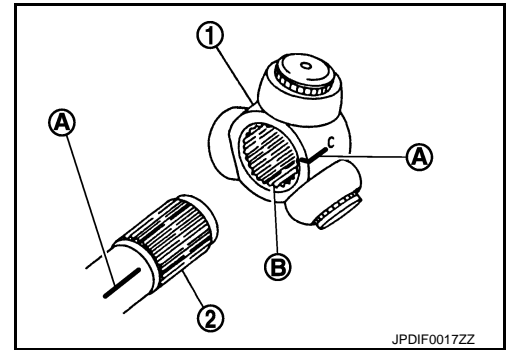

6. Secure spider assembly onto shaft with snap ring (1).
7. Apply the appropriate amount of grease to spider assembly and sliding surface.
8. Assemble the housing onto spider assembly, and apply the balance of the specified amount grease.

### Standard

**Grease amount** : Refer to [FAX-29, "Drive Shaft"](#).

9. Align matching marks painted when housing was removed.
10. Install boot securely into grooves (indicated by "\*" marks) shown in the figure.

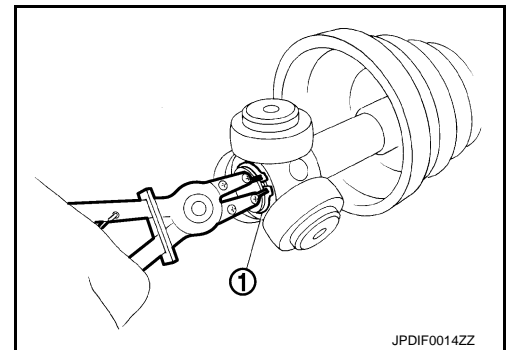

### CAUTION:

**If grease adheres to the boot mounting surface (with "\*" mark) on shaft or housing, boot may come off. Remove all grease from the surface.**

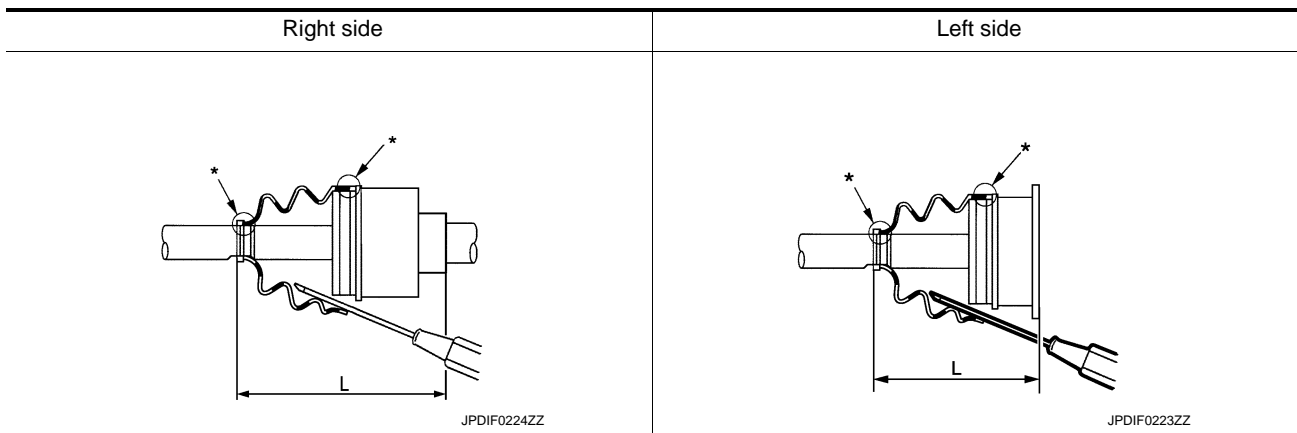

11. To prevent the deformation of the boot, adjust the boot installation length (L) to the value shown below by inserting the suitable tool into the inside of boot from the large diameter side of boot and discharging inside air.

### Standard

**Boots installed length (L)** : Refer to [FAX-29, "Drive Shaft"](#).

### CAUTION:

- If the boot installation length is outside the standard, it may cause breakage of boot.
- Be careful not to touch the inside of the boot with the tip of tool.

12. Install new larger and smaller boot bands securely.

# FRONT DRIVE SHAFT

[AWD]

## < REMOVAL AND INSTALLATION >

- a. For one-touch clamp band
  - i. Secure the large and small ends of a boot with new boot bands as shown in the figure.

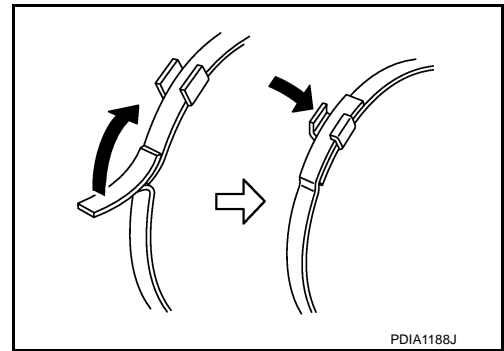

- b. For low profile type band
  - i. Put boot band in the groove on drive shaft boot. Then fit pawls (←) into holes to temporary installation.

**NOTE:**

For the large diameter side, fit projection (A) and guide slit (B) at first.

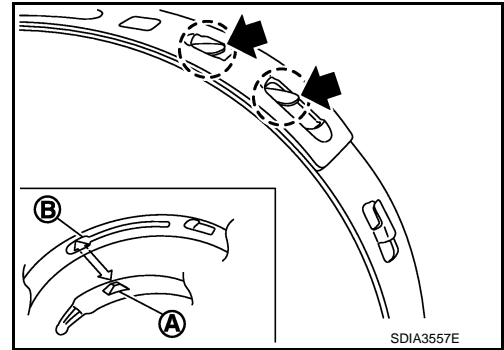

- ii. Pinch projection on the band with suitable pliers to tighten band.
  - iii. Insert tip of band below end of the pawl.
- 13. Secure housing and shaft, and then make sure that they are in the correct position when rotating boot. Install them with new boot band when the mounting positions become incorrect.
  - 14. Install dust cover to housing. (right side)

**CAUTION:**

**Never reuse dust cover.**

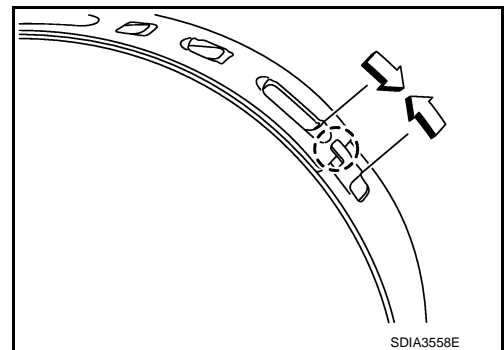

### Wheel Side

For further details on the installation procedure, refer to the installation procedure of "Replacement" for the drive shaft boot.

### Inspection

INFOID:000000007472562

#### INSPECTION AFTER REMOVAL

- Move joint up/down, left/right, and in the axial directions. Check for motion that is not smooth and for significant looseness.
- Check boot for cracks, damage, and leakage of grease.
- Disassemble drive shaft and exchange malfunctioning part if there is a non-standard condition.

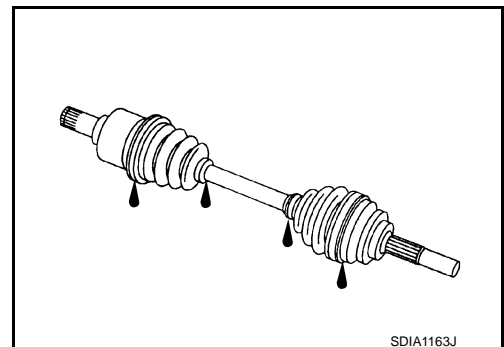

#### INSPECTION AFTER DISASSEMBLY

## FRONT DRIVE SHAFT

< REMOVAL AND INSTALLATION >

[AWD]

### Shaft

Check shaft for runout, cracks, or other damage. Replace if necessary.

### Joint Sub-Assembly (Wheel Side)

Check the following:

- Joint sub-assembly for rough rotation and excessive axial looseness.
- The inside of the joint sub-assembly for entry of foreign material.
- Joint sub-assembly for compression scars, cracks, and fractures inside of joint sub-assembly.

Replace joint sub-assembly if there are any non-standard conditions of components.

### Housing and Spider assembly (Front Final Drive side)

Replace housing and spider assembly if there is scratching or wear of housing roller contact surface or spider roller contact surface.

### **NOTE:**

Housing and spider assembly are used in a set.

# SERVICE DATA AND SPECIFICATIONS (SDS)

< SERVICE DATA AND SPECIFICATIONS (SDS)

[AWD]

## SERVICE DATA AND SPECIFICATIONS (SDS)

### SERVICE DATA AND SPECIFICATIONS (SDS)

#### Wheel Bearing

INFOID:0000000007472563

Item	Standard
Axial end play	0.05 mm (0.002 in) or less

#### Drive Shaft

INFOID:0000000007472564

FAX

Item		Standard	
Joint		Wheel side	Front final drive side
Grease quantity	Left side	77 – 97 g (2.72 – 3.42 oz)	95 – 105 g (3.36 – 3.70 oz)
	Right side		113 – 123 g (3.99 – 4.33 oz)
Boots installed length	Left side	136 mm (5.35 in)	152 mm (5.98 in)
	Right side		158.6 mm (6.24 in)